

PURUS

Installation instruction for PURUS floor gullies dim. 130 mm

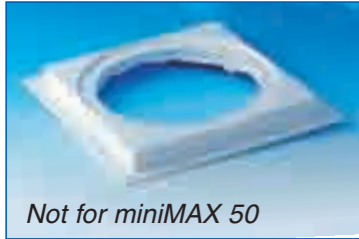

Not for miniMAX 50

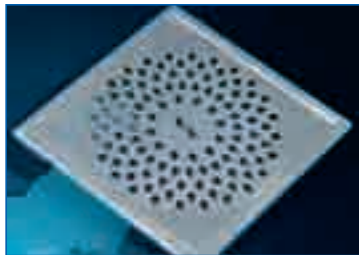

Gratings/frames in 3 different sizes
155x155 mm
175x175 mm
200x200 mm
200x200 mm with circular grating.

The miniMAX floorgullies are CE-marked. All gullies in the PURUS miniserie are approved acc. to EN 1253.

When you choose a floor gully – this is important:

- Most of the PURUS floor gullies are made of PP plastic, which withstands high temperature and have a good resistance to chemicals.
- You cannot glue PP plastic
- When PP plastic is burning, it only forms carbon dioxide and water
- PURUS floor gullies have a clamping ring for vinyl floor and rubber cloth, which automatically adjust itself according to the thickness of the carpet.
- You will always get spare parts for the PURUS floor gullies
- PURUS floor gullies are self cleaning. They need to be inspected/cleaned regularly.
- All PURUS floor gullies can be installed in all types of beams and with all types of flooring



Our ongoing product development may entail changes in version, design and construction, and we reserve the right to make such changes.



PURUS floor gullies are approved acc. to the European standard floor gullies, EN 1253. Approved to be installed in all types of wet areas.

Installing in wooden beams with the PURUS PLATE 130

(1) Reinforce the floor around the floor gully with nogging pieces. Cross bars and nogging pieces should be placed in a distance of approximately 200 mm.

(2) Fasten the PURUS PLATE with suitable screws. E.g. 4x30, Z1 galvanized.

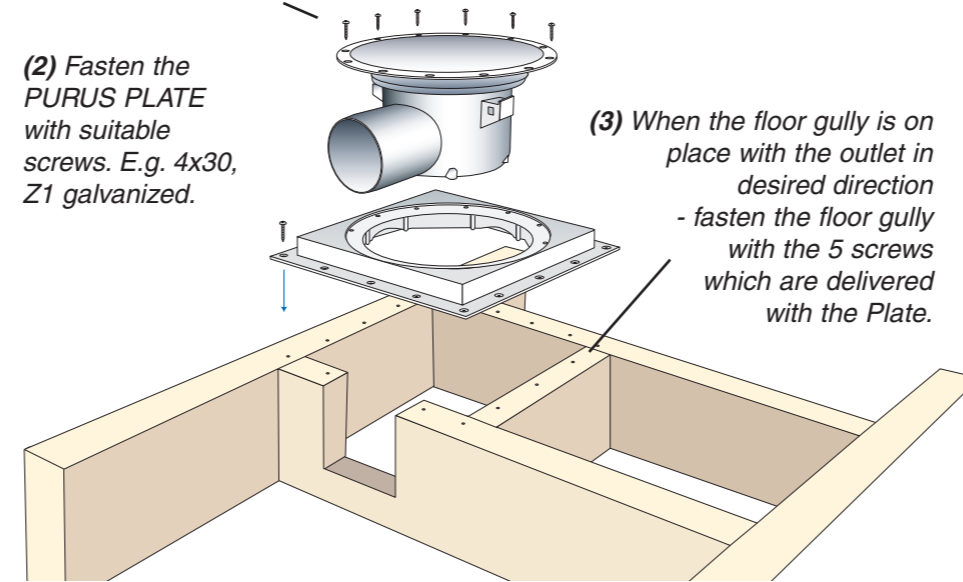

(3) When the floor gully is on place with the outlet in desired direction - fasten the floor gully with the 5 screws which are delivered with the Plate.

(4) Draw the measures of the Plate, 200x200 mm, on the correct place on the particle board. Saw out the hole.

(5) Put the particle board on place.

(6) Fasten the board to the cross bars.

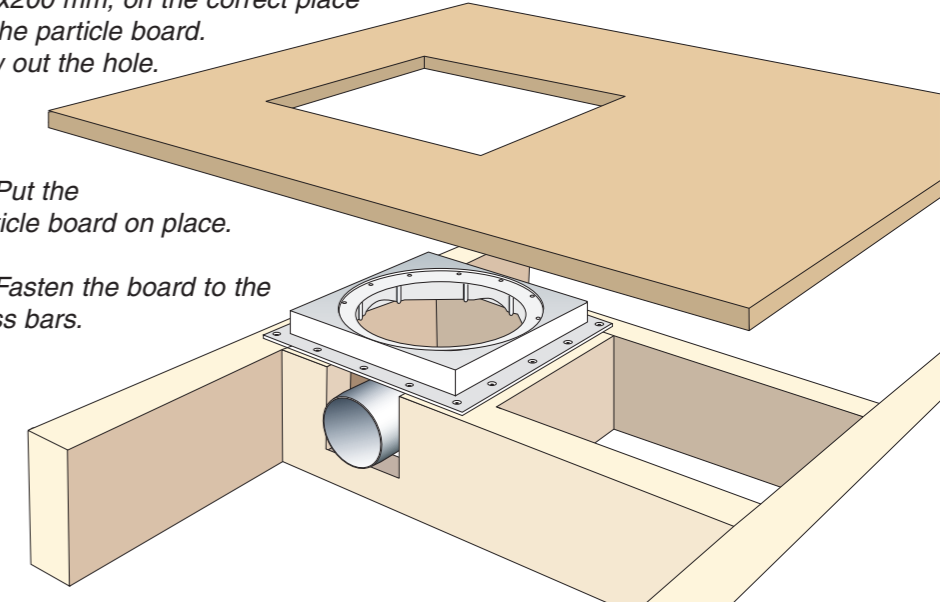

Installing PURUS floor gully in concrete beams

(Alt.1) The floor gully is embedded at the same time as the beams. The floor gully is fixed when connected to the sewer, placed on a batch of concrete, and is lashed to the armoring by lashing wire.

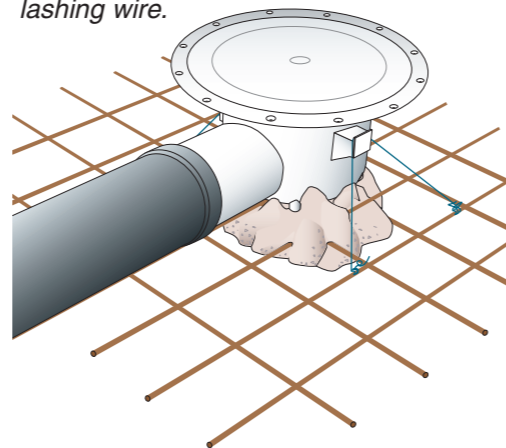

(Alt.2) Recess: when the waste pipe is embedded, a recess is made of e.g. rockwool in the form, with the size 300 x 300 mm.

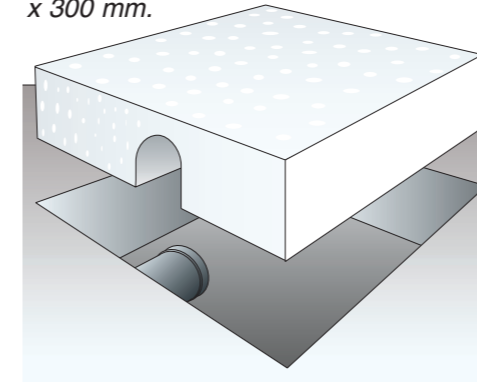

When the concrete has burnt, the floor gully is placed in the recess/hole and is connected to the outlet pipe.

PURUS SUPPORT

is recommended for easy mounting.

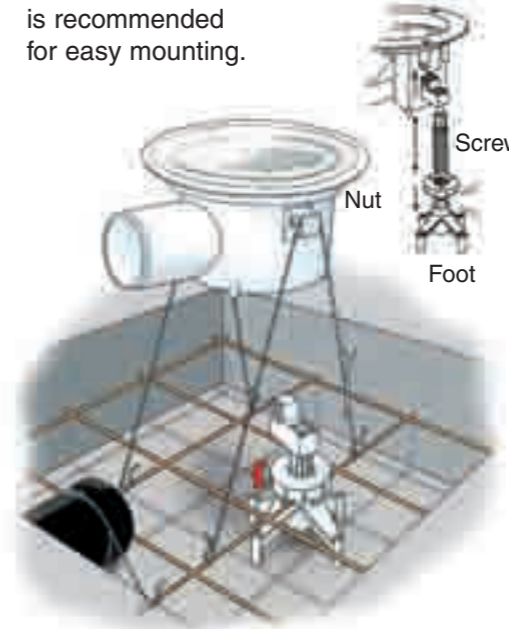

(1) Nail the foot and turn the nuts on both feet up to the right level. The height can be adjusted 60 mm. With an extra sleeve 110 mm.

(2) The floor gully is nailed to the armoring so that it can't be moved during the embedment.

Fall = 1:50

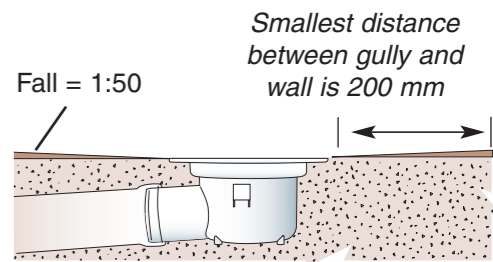

- Keep the protecting cover on, until the last treatment of the flooring is done
- The water trap shall be mounted in the gully.

The Miniserie

A system of floor gullies in dim. 130 mm.

The MINISERIEN are made of polypropenplast (PP).

MINISERIEN has Swedens smallest build-in volume among floor gully systems.

MINISERIEN forefill all demands regarding selfcleaning and temperature resistance.



RSK 711 35 35

MINI ODEN 50

Polypropen complete with water trap, grating and clamping ring. Dim. 130x50 mm.



RSK 711 35 39

MINI BRAGE 50

Polypropen complete with water trap, grating and clamping ring. Dim. 130x50.



RSK 711 35 38

MINI BRAGE 110

Polypropen complete with water trap, grating and clamping ring. Dim. 130x50.

Floor gully MINI MAX 130

PURUS miniMAX in dim. 130 mm

- as floor gully with outlet in dim. 50 and 75 mm
- as outlet funnel with outlet dim. 32, 50 and 75 mm.

PURUS miniMAX has low profile, 70 mm and has a special designed water trap with NOOD-funktion.

The water trap works independently of water in the water trap. Effectively stops back flows, gas leaks, foul air.

The water trap is removeable by the automatic folding handle.

With the water trap removed The Mini Max works as an outlet funnel.



PURUS GRATINGS can be locked



Locking device for plastic grating consists of 2 screws with nuts. Art. No. 713 84 17

Is it possible to use old PURUS products in new PURUS floor gullies?

No. Due to changes in the standards for type approvals, it is not allowed to use accessories produced before 1990 in PURUS floor gullies produced after 1990.

Clamping ring for vinyl floor and rubber cloth



Clamping ring RSK 714 13 16

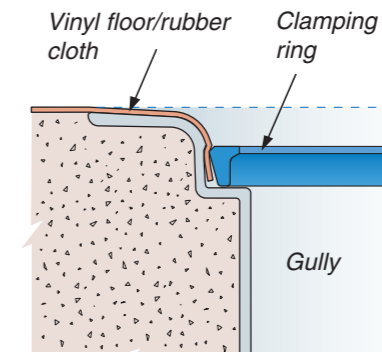

Cleaning and inspection



(1) Pull up the handle and lift off the water trap.



(2) Press the bottom cup down for access
(3) Clean the parts!
(4) Clean the gully with a smooth brush.



(5) Wet the rubber gasket with water and press the water trap in place

(6) Check that it is in right place. Pour in water.

PURUS KNIFE: for cutting hole in the vinyl carpet/membrane



The PURUS knife RSK 711 36 05



(1) Place the the foot of the knife in the floor gully.



(2) Lay the vinyl over the gully and press until the pivot on the foot penetrates the vinyl.



(3) Put the arm of the knife on the pivot (the smallest hole) and cut the hole.



A gentle pressure on the middle of the arm releases the knife holder and the blade



(4) Remove the foot of the knife.

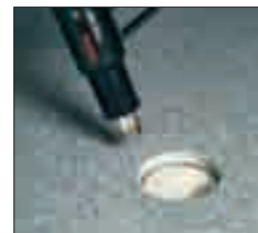

(5) Heat the vinyl. NOTE: rubber cloths shall not be heated.



(6) Place the clamping ring in the gully with the text facing upwards. Press it down with the grating.



To change the blade, the holder is pulled up. Blade: Stanley 5903.

CHECKLIST

- Check that prescribed floor gully is used.
- When choosing mounting place, make sure that it is possible to clean the floor gully.
- The floor gully should be mounted horizontally.
- The upper edge (the flange edge) of the floor gully/extension ring, shall be in level with the surface of the flooring, i.e. in level with the vinyl floor/sealing cover.

PURUS

For more info:
www.purus.se